

2022 PACKING LIST JK (2007-2010)

- (2) 15" **A-STRUTS** (WITH LOCKING TAB)
- (2) 15" **B-STRUTS**
- (2) 18" **G-STRUTS** (WITH RECEIVING HOLE)
- (2) 18" **H-STRUTS**
- (4) **HINGES** (16) **3/8" BUTTON HEAD SCREWS**

- (2) **COTTER PINS**
- (4) **NEOPRENE LANDING PADS**

HARDWARE FOR PANEL STRUTS G & H

- (2) 3/4" CARRIAGE BOLTS *(go into SHADED bolt holes) (see below)
- (6) 5/8" CARRIAGE BOLTS
- (8) LOCKNUTS
- (8) 1/4" WASHERS

HARDWARE FOR STRUTS A and B

- (8) 5/8" CARRIAGE BOLTS
- (8) LOW PROFILE LOCKNUTS
- (8) 1/4" WASHERS

COMPLIMENTARY EXTRAS

- COTTER PIN, LANDING PAD, (2) HINGE SCREWS
- (2) 1/4" WASHERS, (2) LOCKNUTS,
- 5/8" CARRIAGE BOLT, 3/4" CARRIAGE BOLT

LOCTITE PRODUCTS

- REVERSIBLE (BLUE) THREADLOCKER
- GEL GLUE
- PERMATEX SILICONE ADHESIVE (Black)

ASSEMBLIES:

STRUT-A with LOCKING TAB (SECURES TO MAIN ROOF):

STRUT-G with RECEIVING HOLE (SECURES TO PANEL):

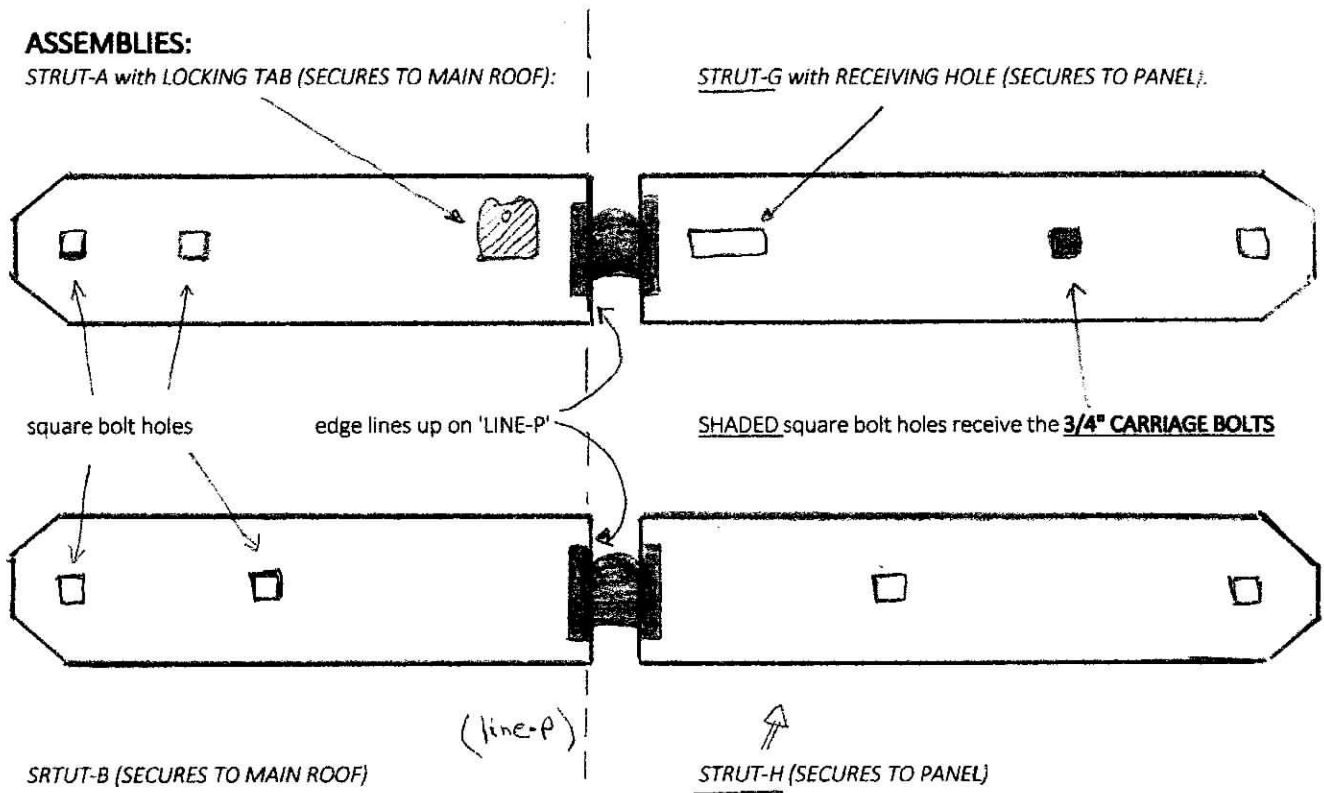

STRUT-B (SECURES TO MAIN ROOF)

STRUT-H (SECURES TO PANEL)

THANK YOU FOR CHOOSING EZUFT

**** please make sure you have ordered the correct year/model. This system is year, model and panel specific.**

Be sure to read ALL the instructions before starting and to familiarize yourself with the included hardware and parts. REFER TO THE PACKING LIST. Loctite and Permatex sealants are included but you will need these additional tools:

Long solid straight edge (yardstick), 1/8th inch Allen wrench, Pencil, Masking Tape, Flat head screwdriver, Drill, 1/4" Drill Bit, 9/32" Drill Bit, 7/16" Socket Wrench or Adjustable Wrench, mineral spirits, and also: for JL/Gladiator models: 5/16th Drill Bit

For your convenience the "Strut and Hinge" Units have been pre-assembled. Note that the 'Assemblies' that have the LOCKING TABS and RECEIVING HOLES are installed closer to the door (on each panel). Also, the 18" Struts are secured to the panels, and the 15" Struts are secured to the main roof (details to follow).

First: Open the assembled units and place against the yardstick. They should line up straight! In the unlikely event that they are no longer aligned due to rough shipping, use the 1/8" Allen wrench to adjust the hinge screws. Make sure you apply a drop of the reversible thread locker before re-securing.

BEFORE STARTING THE INSTALL PROCESS:

**** YOU NO LONGER NEED TO REMOVE THE SOUNDBAR TO INSTALL ****

- (1) **Make sure your panels are locked in place and seated evenly.** The spacing around the panels and roofline should be uniform.
- (2) Cover the seats to avoid getting them dirty when you drill
- (3) Identify your Assemblies. there are (2) with locking tabs and (2) without. Each panel receives one of each, and the Assembly with the locking tab is always closer to the door. The 15" Struts secure to the main roof and the 18" struts secure to the panels. ***The placement is year/model specific. See diagram included with these instructions. On-line videos are to help with technique, but video segments may not be specific to your year/model.**

GENERATE THE ALL IMPORTANT "LINE-P"

This line is an 'extension' of the straight section where your main roof meets both panels. It is **extrapolated on the main roof** extending to both sides of the Jeep. (driver side and passenger side). **SEE DIAGRAM THAT FOLLOWS**

Use the long straight edge to draw the extensions of this line and **BE STRAIGHT.** (avoid drawing on your roof by first laying down a strip of Masking Tape, then drawing the accurate extension of the line on the tape). The 'Assembled' Strut and Hinge systems cross 'Line-P' and this is **THE "LINE-P" ON WHICH THE HINGE-SIDE OF THE 15"-STRUTS LINE UP.** **SEE DIAGRAM THAT FOLLOWS**

GENERATING "LINE -P".

- LOCATE THE STRAIGHT SEAM WHERE THE MAIN ROOF CONNECTS WITH BOTH FREEDOM PANELS (BEFORE THE PANELS START TO CURVE).
- *USE A PENCIL AND A STRAIGHT-EDGE TO EXTRAPOLATE THIS SEAM (LINE) FROM THE DRIVERS SIDE TO THE PASSENGERS SIDE. (AVOID DRAWING ON YOUR ROOF BY RUNNING A STRIP OF PAINTERS TAPE TO APPROXIMATE THE LINE). USE THE YARDSTICK STRAIGHT EDGE TO ACCURATELY EXTRAPOLATE THE TOP-EDGE OF THIS SEAM-LINE FROM SIDE TO SIDE ALONG THE MAIN ROOF. YOU HAVE CREATED 'LINE-P'
- *THE HINGE-SIDE EDGE OF THE 15" STRUTS (FOR EACH ASSEMBLY) IS POSITIONED ON THE "LINE- P".
- *THE DIFFERENT STRUT ASSEMBLIES (MODEL AND YEAR SPECIFIC) ARE POSITIONED ABUTTING SPECIFIC RIDGES, AND CROSS FROM THE 'MAIN ROOF' ONTO THE 'FREEDOM PANELS'. (THE RIDGES USED ARE ALSO SPECIFIC FOR THE YEAR OF YOUR ROOF/PANEL)
- *USE THE **DIAGRAM ON THE NEXT PAGE FOR THE CORRECT PLACEMENT OF THE STRUT ASSEMBLIES**. (THIS MAY ALSO BE FOUND UNDER THE 'INSTALL' SECTION ON THE WEBSITE). VIDEOS ARE AVAILABLE FOR AN EXAMPLE OF TECHNIQUE.

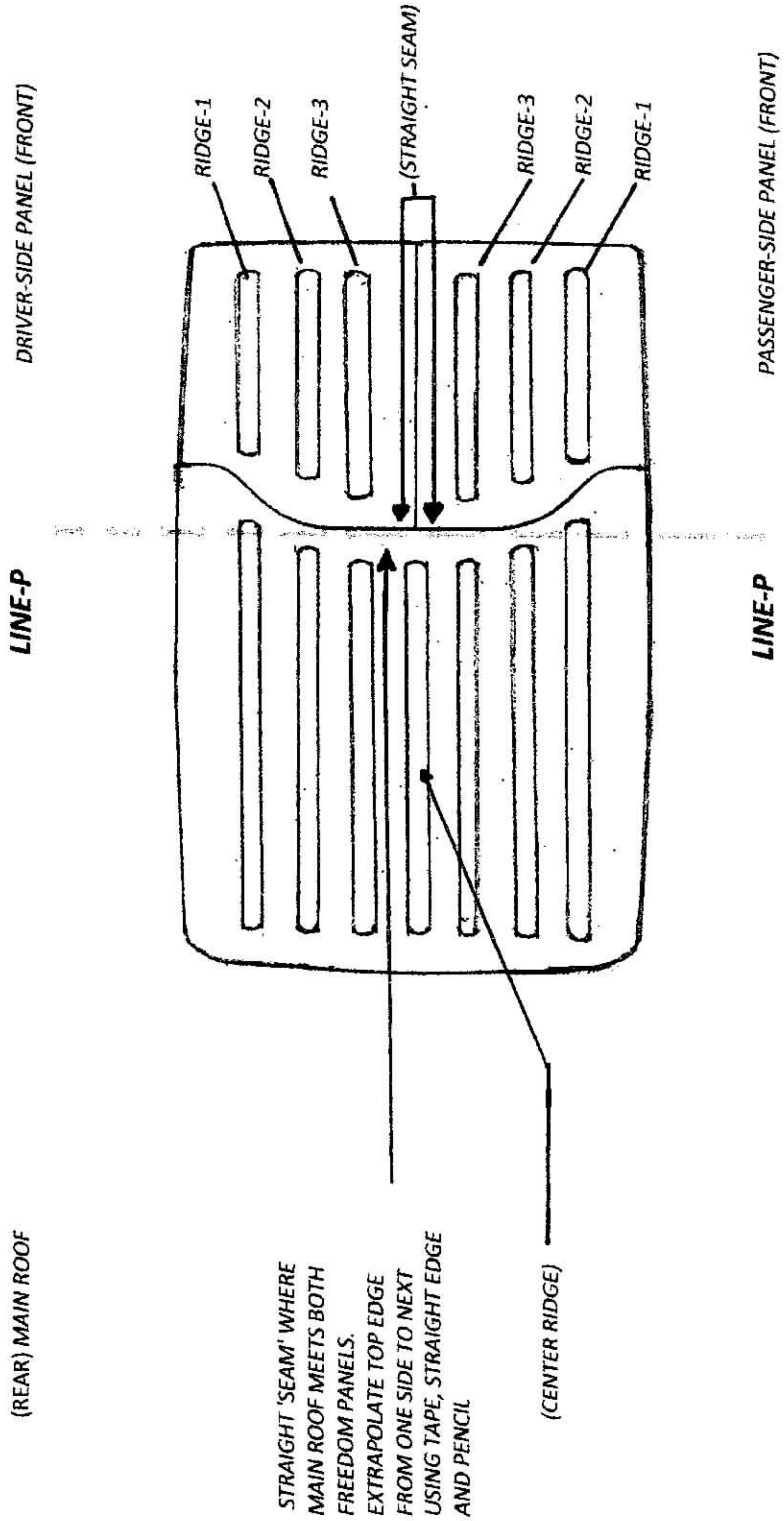

NEXT UP: CORRECT PLACEMENT OF THE 'ASSEMBLIES'

The Strut and Hinge 'Assemblies' you have ordered are year/model and panel specific. Their placement on the roof/panels is also location specific. Use the diagram below to tape the 'correct assembly' to the 'correct location' on top of your Jeep. Each 'Assembly' is composed of a 15" Strut and an 18" Strut. The 15" Struts secure onto the main roof with their 'hinge-side end' sitting ON 'LINE-P'. The rest of the assembly extends on to the panels. The 18" struts secure to the panels.

THE ROOF TOP RIDGES DETERMINE THE SPACING OF YOUR 'ASSEMBLIES'.

FOLLOW THE DIAGRAM BELOW: (1) LINE UP ON 'LINE-P' (2) MAKE SURE THE ASSEMBLIES ARE COMPLETELY FLAT, (3) MAKE SURE THE ASSEMBLY IS EVENLY ABUTTED UP AGAINST THE CORRECT SIDE OF THE CORRECT RIDGE. TAPE EACH ASSEMBLY SECURELY INTO PLACE.

JK MODEL (2007-2010)

There is one [A-G] and one [B-H] ASSEMBLY per panel. The [A-G] ASSEMBLY with its TAB and Receiving Hole, near the door but on the far side of RIDGE-1. The [B-H] Assembly sits on the closer/door side of RIDGE-3. Follow the diagram below. TAPE EACH ASSEMBLY IN PLACE. DO NOT place tape over the square bolt holes!!

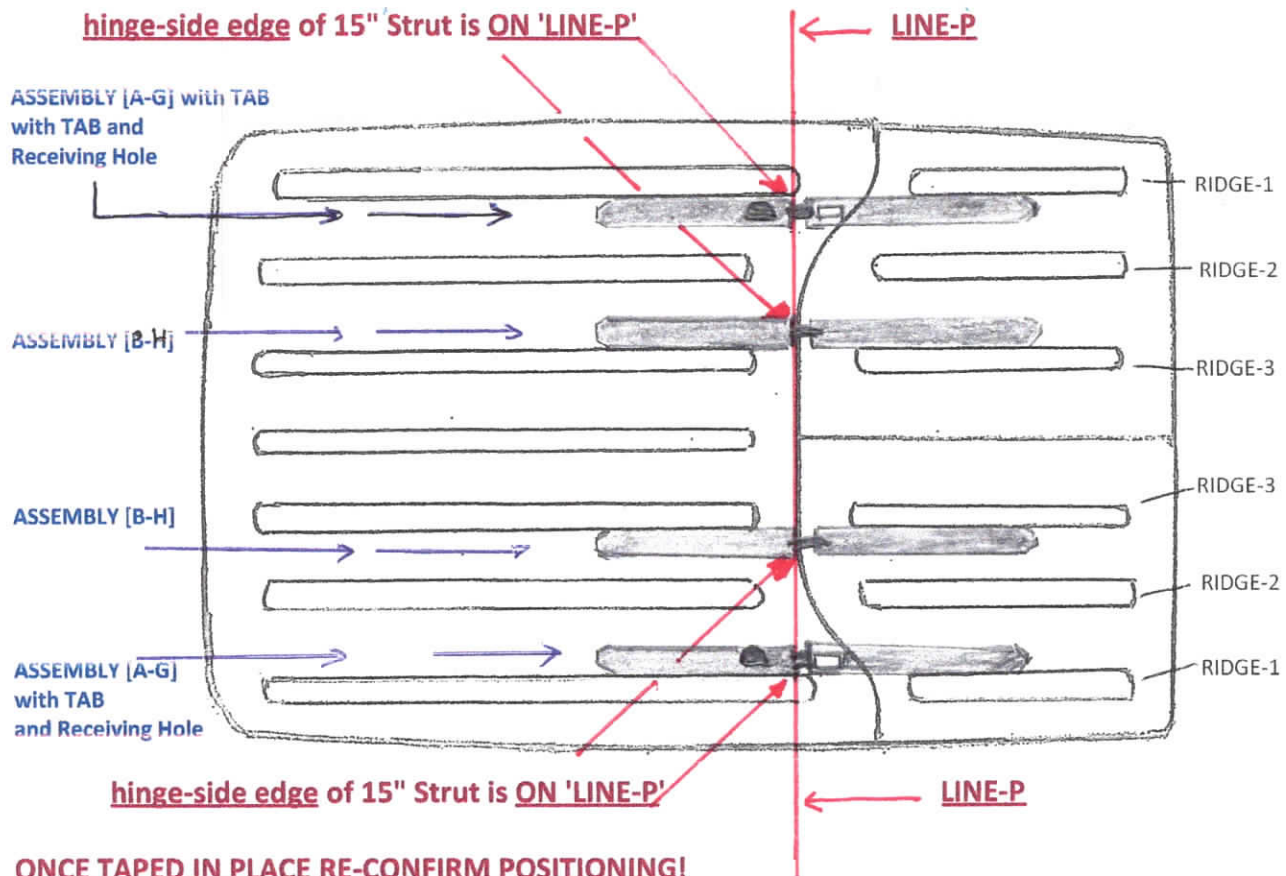

ONCE TAPED IN PLACE RE-CONFIRM POSITIONING!

*** USING A MEASURE, CONFIRM THAT THE ASSEMBLIES ON EACH PANEL ARE PARALLEL TO EACH OTHER (SAME DISTANCE APART THROUGH-OUT) ON THE MAIN ROOF AND ON THE PANELS ***

'TIME TO DRILL' YOUR JK (2007-2010) MODEL

WITH THE 'ASSEMBLIES' TAPED IN PLACE YOU NOW HAVE YOUR TEMPLATES FOR **'MARKING'** THE BOLT HOLES.

FAMILIARIZE YOURSELF WITH THE HARDWARE PACKETS, THEY HAVE BEEN SORTED TO MAKE IT EASIER: Hardware for Struts A and B (used on main roof: *5/8" Carriage Bolts, 1/4" washers and locknuts*). Hardware for Struts G and H (on Freedom Panels: *is a mix of 5/8" and 3/4" Carriage Bolts, washers & locknuts*). **** refer to the packing list to see which 'Freedom-Panel' bolt-hole receives the 5/8" Carriage Bolts vs the 3/4" Carriage Bolt.**

Layout your tools and double check that you have covered the seats!!

When **'MARKING'** the holes for drilling, and to ensure you find the true center of the square bolt hole, start by using the 9/32 drill bit (*with light pressure and a few revolutions*) to create a **'SMALL DIVOT only'**. **** DO NOT DRILL COMPLETELY THROUGH** the roof or the panels with this 9/32 drill bit!!

ONCE YOU HAVE CREATED ALL YOUR DIVOTS (16 IN TOTAL), YOU MAY REMOVE THE ASSEMBLIES AND ALL THE TAPE, INCLUDING THE TAPE FOR MARKING 'LINE-P'.

WITH THE DIVOT AS YOUR GUIDE USE THE 1/4" DRILL BIT TO DRILL THROUGH THE ROOF OF YOUR JEEP. MAKE SURE YOU ARE PERPENDICULAR TO THE ROOF WHEN DRILLING.

REMOVE ANY DEBRIS FROM THE ROOF-TOP AND **CLEAN THE ROOF AND THE UNDERSIDE OF THE ASSEMBLIES** TO PREP FOR INSTALLATION (MINERAL SPIRITS WORK).

MAKE SURE YOUR ASSEMBLIES ARE IN AN ORDER TO AVOID CONFUSION ABOUT WHICH GOES WHERE.

START ON THE DRIVERS SIDE WITH THE CLOSEST 'A-G' ASSEMBLY (THIS HAS THE LOCKING TAB AND RECEIVING HOLE). **FLIP IT OVER**, BEGIN WITH THE 15" 'STRUT-A' AND APPLY A CONTINUOUS 1/8 " BEAD OF PERMATEX SILICONE ADHESIVE (JUST CUT THE VERY TIP OF THE DISPENSER). APPLY A CONTINUOUS BEAD TO ENCIRCLE THE BOLT HOLES AT A 1/2" DISTANCE FROM THE BOLT HOLES AND THEN ZIG/ZAG TO WITHIN 1/2" OF THE HINGE AS SHOWN (SEE NEXT DIAGRAM)

****ON THE (18") 'STRUT-G' WITH THE RECEIVING-HOLE, APPLY THE SILICONE TO WITHIN 1" OF THE RECEIVING-HOLE AND NOT CLOSER. ** DO NOT** RUN THE ADHESIVE BEYOND THIS POINT OR HEAD TOWARDS THE HINGE. ****THIS STRUT CROSSES FROM THE 'FREEDOM-PANEL' ONTO THE MAIN- ROOF AND SHOULD ONLY HAVE ITS ADHESIVE PUT ON THE 'PANEL-SIDE PORTION'.**

****NOTE: THE ADHESIVE APPLIED TO THE FRONT-PANEL 'STRUTS' SHOULD NOT EXTEND INTO THE SEAM BETWEEN THE MAIN ROOF AND THE PANEL. MAINTAIN A 1/2" DISTANCE FROM THE SEAM.**

(SEE NEXT DIAGRAM)

DIAGRAM FOR ADHESIVE APPLICATION: (WIPE UNDERSIDE OF STRUT 'ASSEMBLIES' AND TURN THEM OVER:)

(15") STRUT-A (tab not seen, as is on flip side).

CONTINUOUS BEAD AT 1/2" AROUND SQUARE BOLT HOLES AND THEN ZIG-ZAG AS SHOWN TO 1/2" FROM HINGE

(18") STRUT-G (with receiving hole)

STOP ZIG/ZAG @ 1/2" to 1" FROM RECEIVING HOLE. DO NOT EXTEND TOWARD THE HINGE. KEEP 1/2" FROM ANY NEARBY SEAM

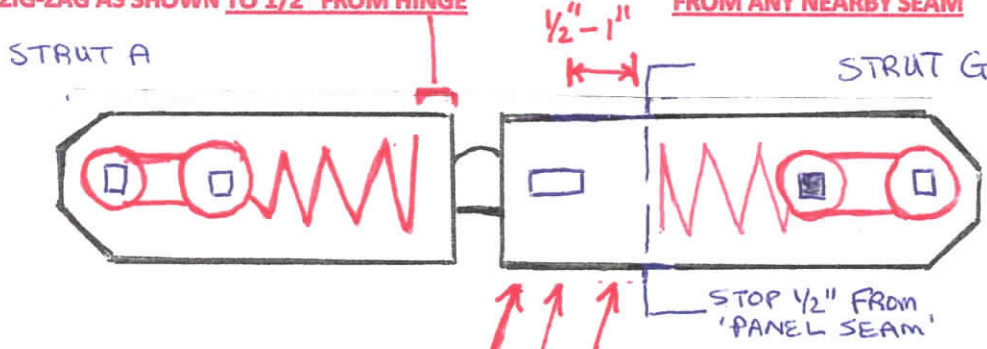

"SHADED" SQUARE BOLT HOLE GET 3/4" CARRIAGE BOLT

STRUT B

NO ADHESIVE HERE (PART OF 18" STRUT SITTING ON MAIN ROOF)

STRUT H

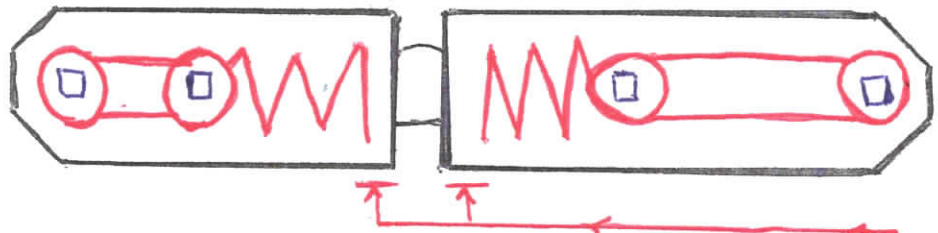

CIRCLE WITH BEAD 1/2" FROM BOLT HOLES; ZIG/ZAG TO 1/2" OF HINGE & SEAM

(15") STRUT-B (on flip side)

(18") STRUT-H (on flip side)



RUN A CONTIN. BEAD AROUND SQUARE NECK OF CARRIAGE BOLT

FLIP YOUR 'ASSEMBLY' RIGHT SIDE UP AND GENTLY POSITION THE SQUARE BOLT HOLES OVER THE DRILLED HOLES (drop a temporary carriage bolt in to help line it up, or use masking tape if needed). Apply gentle pressure to seat the Assembly and wipe away any XS adhesive.

WITH 'ASSEMBLY' IN PLACE START INSERTING HARDWARE.

Note: Rear main-roof Carriage Bolts (5/8") are secured with the 1/4" washers and low-profile locknuts (using the wrench)

Before inserting the Carriage Bolts: run a continuous bead of Permatex Adhesive around the "Square-Neck" of the bolt: insert into 1/4" drill hole and secure lightly with washer and locknut. Apply counter pressure to head of carriage bolt while doing this.

The 'Panel-Top' Carriage Bolts (3/4") and (5/8") go in the bolt holes shown on the packing list, and get secured with the 1/4" washers, the locknuts and the wrench.

Again, run a continuous bead of Permatex Adhesive around the "Square-Neck" of the carriage bolt before inserting into the 1/4" drill hole. Apply counter pressure to head of Carriage bolt when securing. Once all the hardware is in place for the Assembly, tighten firmly from inside. Recheck for, and wipe off any, additional adhesive that may have squeezed out.

REPEAT FOR OTHER 'ASSEMBLIES'

THE FINAL STEPS JK (2007-2010) MODEL INSTALL

WITH ALL 4 OF THE 'ASSEMBLIES' (BOTH PANELS) INSTALLED, WAIT AN HOUR FOR THE ADHESIVE TO BOND UP A BIT. GET READY TO TEST YOUR PANELS AND BE PREPARED TO POSITION AND INSTALL THE **NEOPRENE LANDING PADS**. MEASURE FROM THE 'POINTY END' OF THE REAR STRUTS. **MEASURE 16" BACK TOWARDS THE REAR OF THE JEEP AND MARK ACROSS RIDGES (2) AND (3)**. (DO SO FOR BOTH PANELS). BASICALLY, STAY PARALLEL TO 'LINE-P'. **NEXT: POSITION (BUT DO NOT GLUE) THE PADS ONTO RIDGES 2 AND 3 (TO SPAN THE RIDGE) WHERE MARKED.**

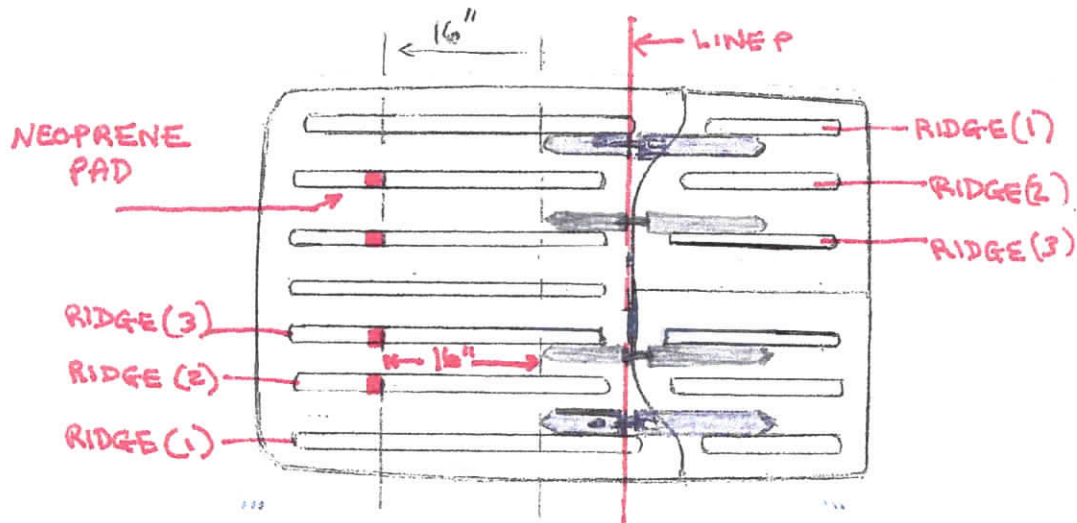

UNLATCH THE FREEDOM PANELS. **REMOVE THE LONG SCREWS THAT SECURE THE REAR OF THE PANELS. YOU CANNOT OPEN YOUR PANEL WITH THESE IN PLACE.** STARTING WITH THE DRIVERS SIDE, PUSH UP ON THE MIDDLE UNDERSIDE (NEAR THE FRONT END) OF THE PANEL. THEN GRAB THE SIDE EDGE OF THE PANEL AND ROTATE THE PANEL TO REST GENTLY ON THE MAIN ROOF. **THE PANELS REST ON THE NEOPRENE PADS AND DO NOT ACTUALLY TOUCH THE TOP OF THE MAIN ROOF. REPEAT FOR THE PASSENGER SIDE. EVERYTHING SHOULD LAY EVENLY IN PLACE. **(IMPORTANT: ***SEE NOTE BELOW)** NEXT: GENTLY CLOSE THE PASSENGER SIDE AND THEN DRIVER SIDE PANEL. OUTLINE THE POSITION OF EACH PAD. APPLY LOCTITE SUPER GEL GLUE (A LITTLE ALL-OVER THE PAD, BUT NOT SO MUCH THAT IT WILL SQUEEZE ONTO THE ROOF AS IT IS DIFFICULT TO CLEAN). PRESS AND HOLD IN PLACE FOR 60 SECONDS.

NOTE: *WHEN CLOSING YOUR FREEDOM PANELS,** YOU MAY FIND THAT THE FRONT GUIDE-PINS DO NOT WANT TO DROP INTO THEIR USUAL HOLES SMOOTHLY. THIS IS BECAUSE OF THE NEW ANGLE OF CLOSURE. TO CORRECT THIS, YOU CAN UNSCREW AND REMOVE THESE GUIDE-PINS PERMANENTLY (OR FILE THEM DOWN AT AN ANGLE).

WE DO RECOMMEND ALLOWING THE ADHESIVES TO DRY FOR AT LEAST 24 HOURS BEFORE USING, AND TO KEEP 'DRY FOR 48 HOURS'. THIS WILL ALLOW THE LOCTITE AND PERMATEX PRODUCTS TO ADHERE PROPERLY.

NOW YOU ARE FREE TO **'FLIP LOCK AND GO'**. WHEN IN THE 'OPEN-POSITION' USE THE PROVIDED SS COTTER PINS TO LOCK IN PLACE. INSERT THE BASE OF PIN THROUGH THE HOLE OF THE LOCKING TAB, ITS TOP WILL SEAT IN THE GROOVE OF THE TAB. AIR CAN PASS UNDER AS WELL AS OVER THE PANELS MAKING THE SYSTEM VERY AERODYNAMIC AND SECURE. WHEN CLOSING UP: FIRST REMOVE THE COTTER PIN, (DO NOT CRANK ON THE PANEL WITH THE PIN IN PLACE), (STOW COTTER PIN IN JEEP), BRING THE PANELS AROUND AND GENTLY DROP IN PLACE. **IT WILL WORK LIKE A CAR DOOR EVERY TIME.**

WE HOPE YOU ENJOY THE CONVENIENCE OF YOUR NEW **'FLIP LOCK AND GO' EZUFT SYSTEM.** KEEP THE SAFETY AND SECURITY OF YOUR HARDTOP, WITHOUT MESSING WITH YOUR FACTORY SEALS. NO NEED TO PLAN AHEAD OR WORRY ABOUT THE WEATHER. NO CUMBERSOME STOWING OF TOPS OR USING UP THE CARGO SPACE. AND: NO SCRATCHING, NO RATTLING AND NO RUST. FEEL SECURE KNOWING YOUR SYSTEM IS MADE OF HEAVY-DUTY MARINE GRADE ALUMINUM, BOLTED DOWN WITH STAINLESS STEEL HARDWARE, UTILIZING HEAVY DUTY MARINE GRADE ZINC HINGERS RATED FOR OVER 22,000 REPETITIONS.

OPEN AND CLOSE IN 60 SECS OR LESS: WHEREVER, WHENEVER AND AS OFTEN AS YOU LIKE. JUST BECAUSE YOU CAN! WE KNOW YOU WILL APPRECIATE THE NO-HASSEL FREEDOM.